

NOTES:

1. THIS DETAIL SHOWS THE TYPICAL FINAL WATER METER CONFIGURATION AFTER INSTALLATION OF A PROPOSED WATER METER, RECONNECTION OF AN EXISTING WATER METER, OR RELOCATION OF A WATER METER.

1-24  
 STATE OF  
 NORTH CAROLINA  
 DEPT. OF TRANSPORTATION  
 DIVISION OF HIGHWAYS  
 RALEIGH, N.C.

ROADWAY STANDARD DRAWING FOR  
**WATER METER**

NOTES:

1. THIS DETAIL SHOWS THE TYPICAL FINAL FIRE HYDRANT CONFIGURATION AFTER INSTALLATION OF A PROPOSED FIRE HYDRANT, RECONNECTION OF AN EXISTING FIRE HYDRANT, OR RELOCATION OF A FIRE HYDRANT.
2. KEEP DRAIN PORTS FREE FROM OBSTRUCTION.
3. RESTRAIN ALL PIPE JOINTS AND FITTINGS. ACCEPTABLE TYPES OF RESTRAINT INCLUDE RESTRAINING GLANDS; RESTRAINED, PUSH-ON JOINTS; AND 3/4" BITUMINOUS COATED, ALL-THREAD RESTRAINING RODS. THRUST BLOCKS ARE NOT AN ACCEPTABLE TYPE OF RESTRAINT.
4. FOR RELOCATED OR RECONNECTED FIRE HYDRANTS, VERIFY THE VALVE IS RESTRAINED TO THE MAIN. PROVIDE APPROPRIATE RESTRAINT.

5. HYDRANT LOCATION APPLIES TO PROPOSED AND RELOCATED FIRE HYDRANTS.
6. LOCATE FIRE HYDRANT WITH 3' HORIZONTAL CLEARANCE FROM ABOVE GROUND OBJECTS.
7. PROVIDE A MINIMUM OF 3' COVER OVER ALL SECTIONS OF HORIZONTAL PIPE. USE FITTINGS AS NECESSARY.
8. TAPPING SLEEVES MAY BE USED ON EXISTING MAINS IN LIEU OF DI TEES.
9. LOCATE FIRE HYDRANT OUTSIDE OF THE VEHICLE RECOVERY AREA, ADJACENT TO THE R/W LINE, OR IN A PROTECTED AREA.

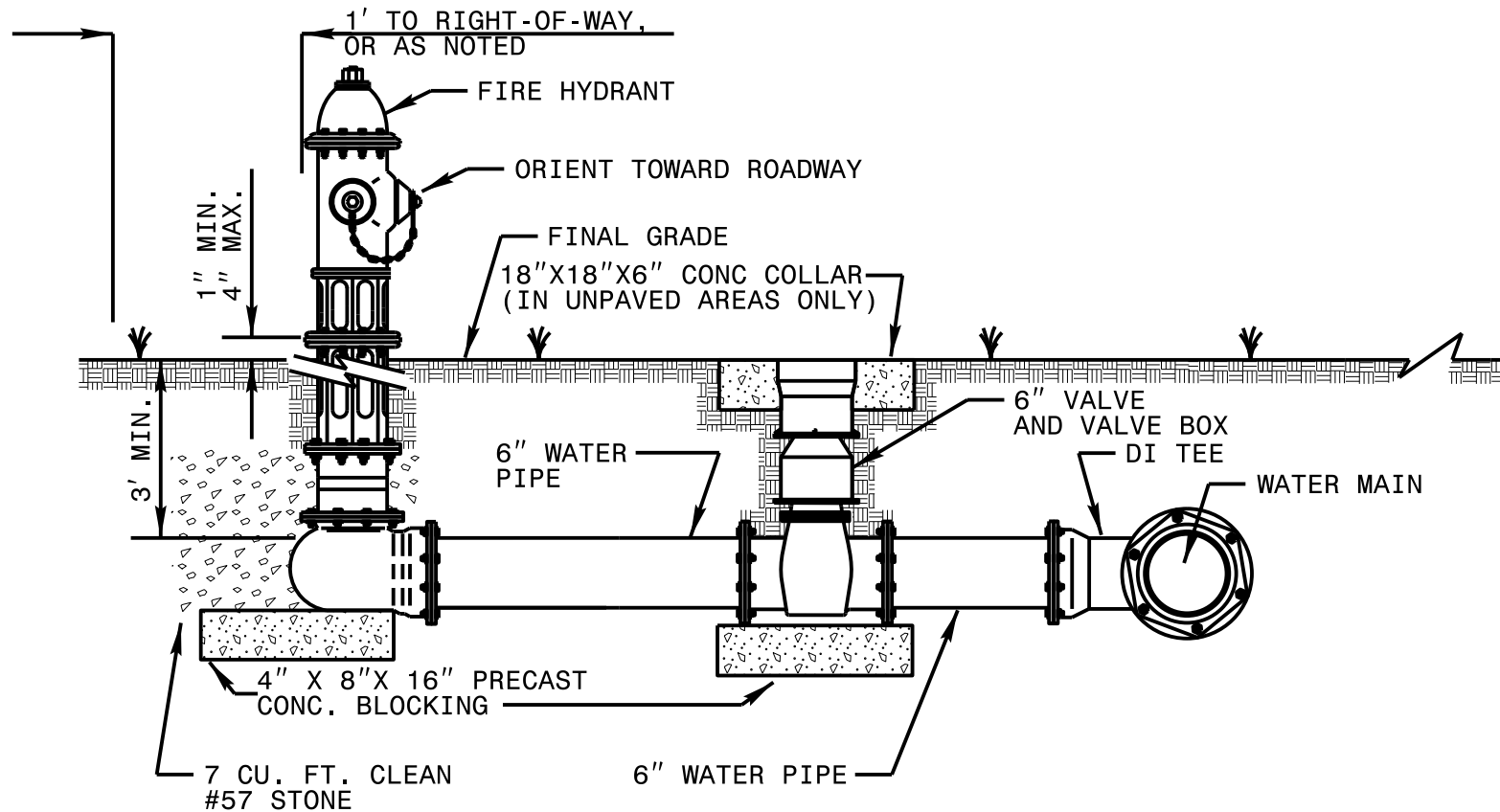

1-24  
 STATE OF  
 NORTH CAROLINA  
 DEPT. OF TRANSPORTATION  
 DIVISION OF HIGHWAYS  
 RALEIGH, N.C.

ROADWAY STANDARD DRAWING FOR  
**FIRE HYDRANT**

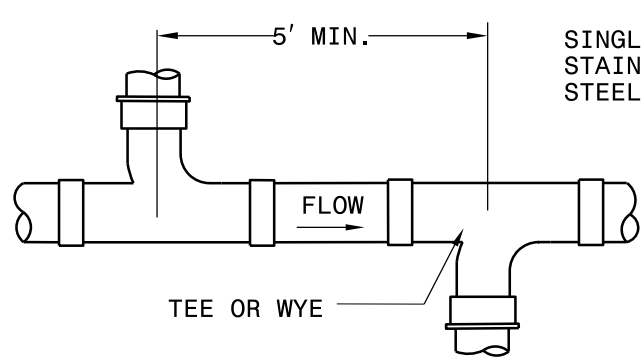

**TEE WYE CONNECTION  
OPTIONAL**

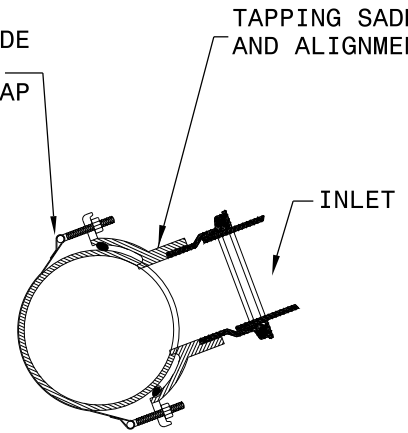

**TAPPING SADDLE  
OPTIONAL**

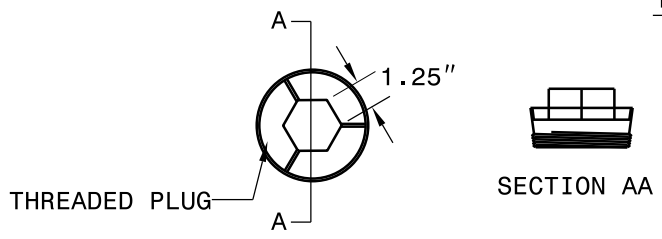

**UNPAVED AREA CAP**



**PAVED AREA CAP**

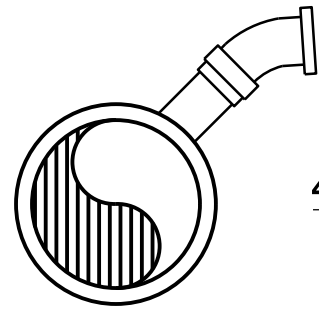
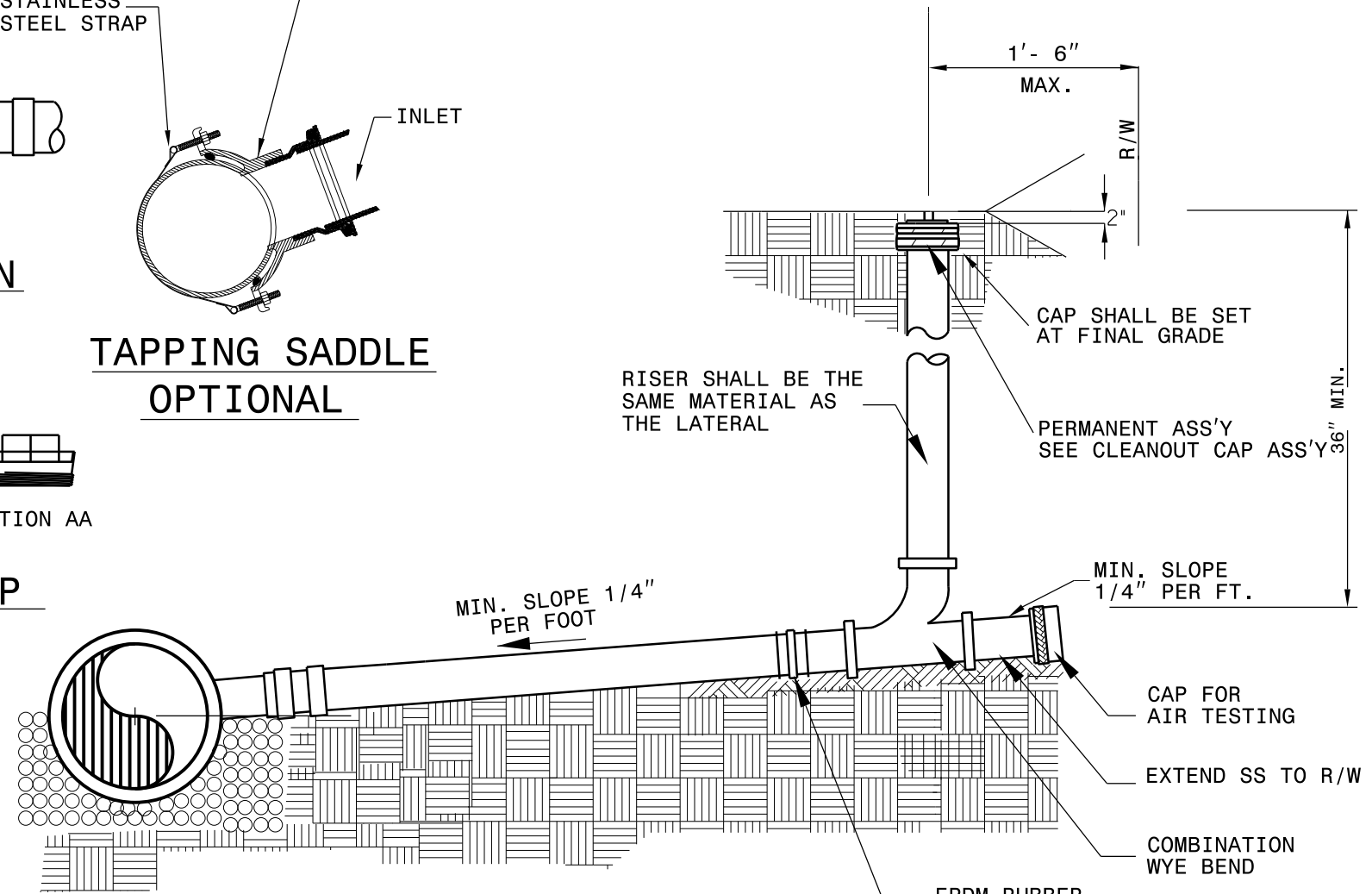

**INLET WITH  
45 DEGREE BEND  
OPTIONAL**

**NOTES:**

1. THIS DETAIL SHOWS THE TYPICAL FINAL CONFIGURATION OF A PROPOSED SEWER CLEAN OUT, A RELOCATED SEWER CLEAN OUT, OR A RECONNECTED SEWER CLEAN OUT.
2. USE 45 DEGREE VERTICAL BEND AT INLET IF GRADE ALLOWS.

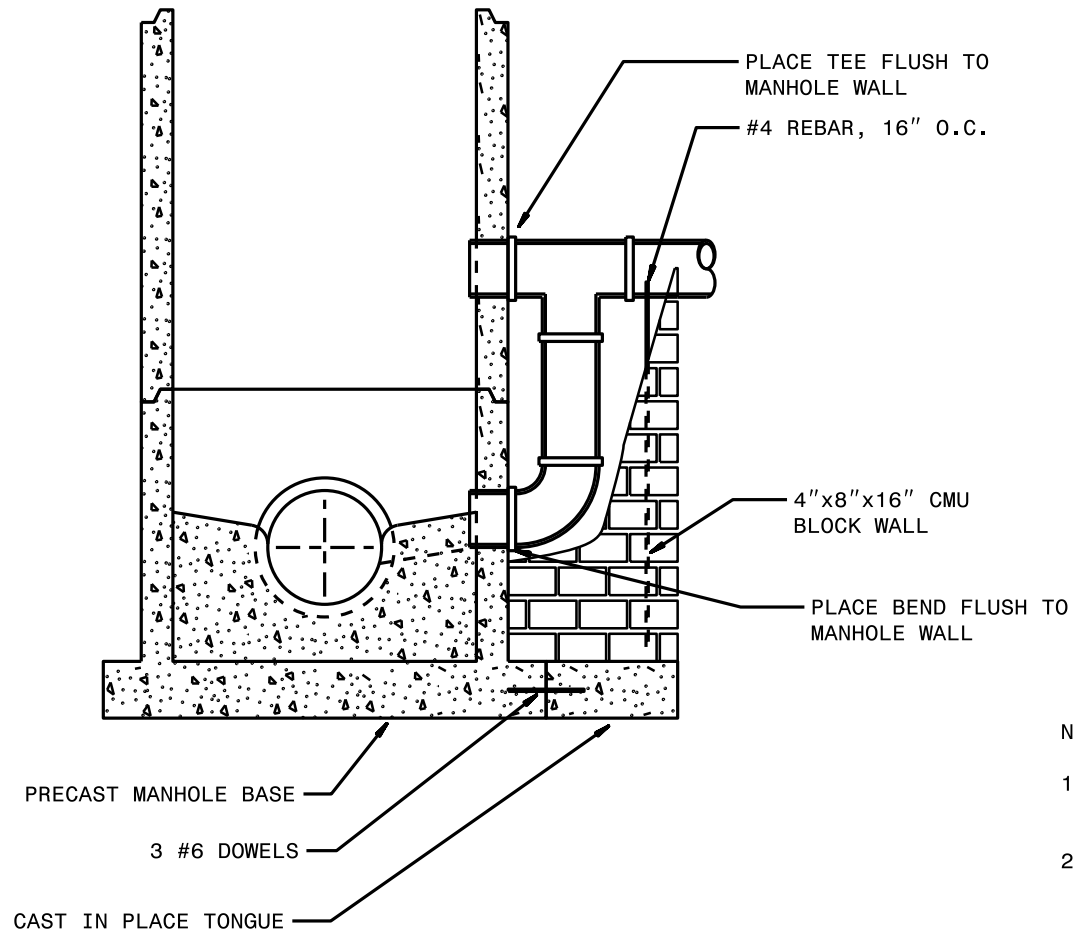

**SECTION X-X**

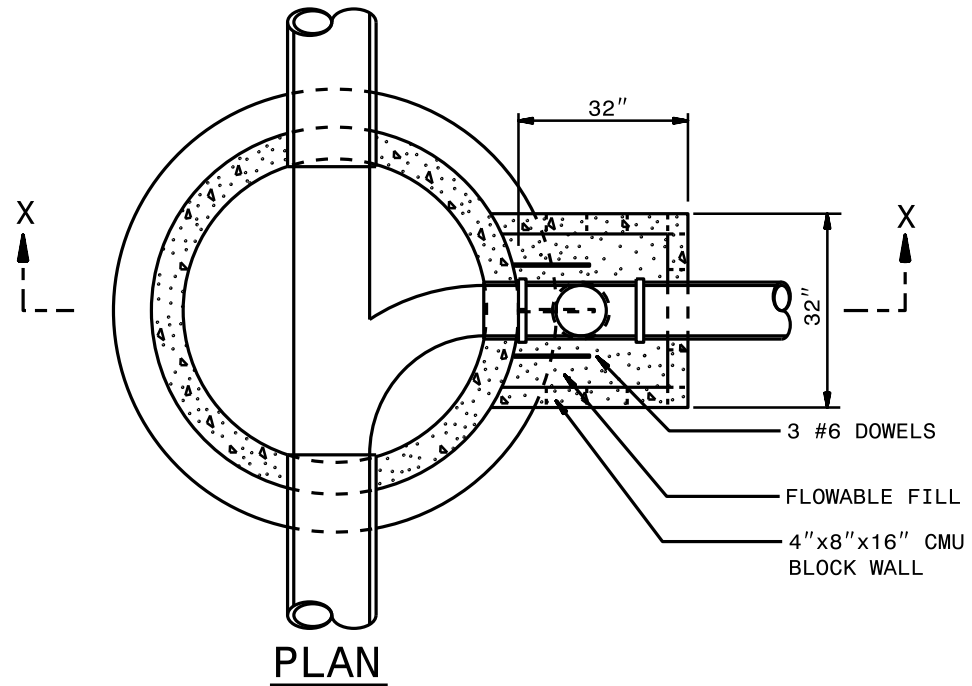

**PLAN**

**NOTES:**

1. THIS DETAIL SHOWS THE CONFIGURATION OF AN OUTSIDE DROP WITH A PRECAST CONCRETE MANHOLE.
2. INSERT THREE #6 DOWELS INTO THE BASE OF THE PRECAST MANHOLE BEFORE POURING CAST IN PLACE TONGUE. FACTORY DRILL OR CAST THE DOWEL HOLES IN THE BASE. EPOXY THE DOWELS INTO PLACE. EMBED DOWELS A MINIMUM OF 6" INTO THE MANHOLE BASE AND THE TONGUE. CENTER DOWELS VERTICALLY AND HORIZONTALLY. PLACE DOWELS 12" ON CENTER.
3. BLOCK WALL TO SPRING LINE OF HORIZONTAL PIPE.
4. USE FOR DROP INLET PIPES UP TO 12".
5. USE PC 350 DUCTILE IRON PIPE and FITTINGS FOR THE DROP ASSEMBLY. THE DROP ASSEMBLY SHALL BE THE SAME PIPE DIAMETER AS THE INLET PIPE.

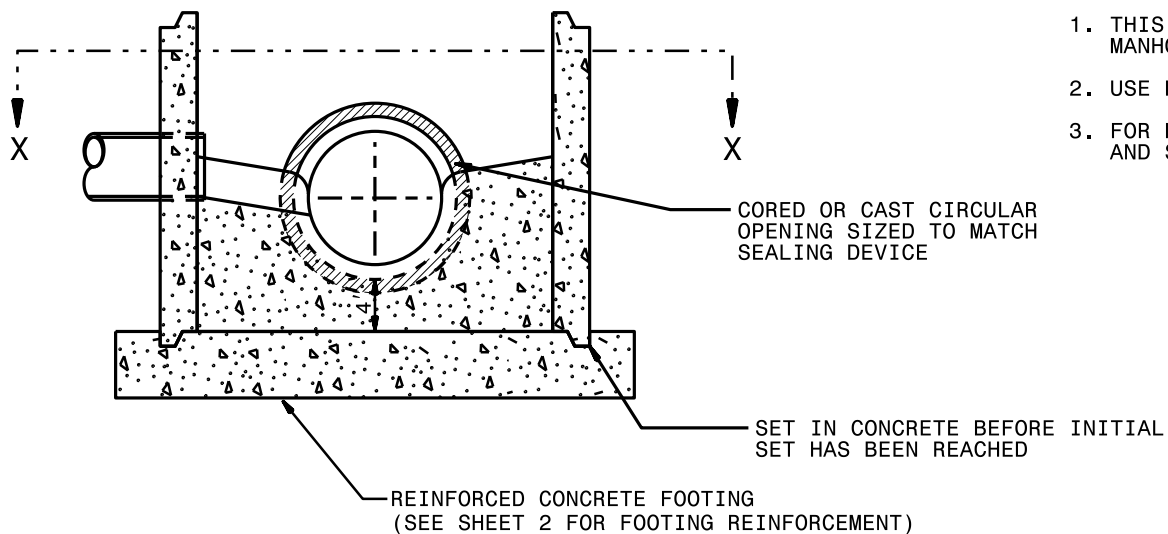

**SECTION Y-Y  
CORED PIPE TYPE**

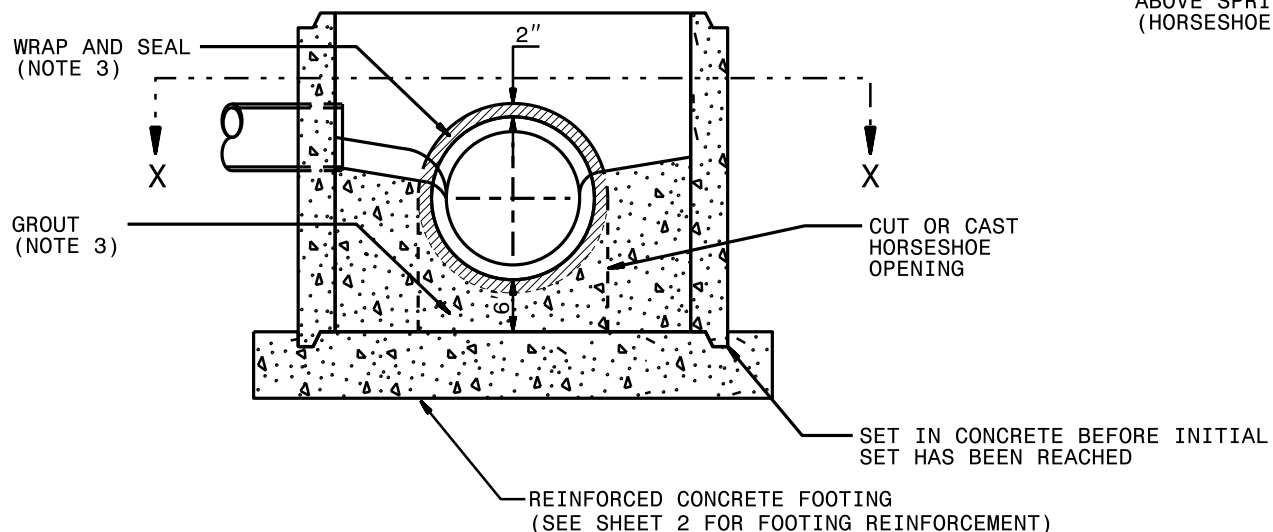

**SECTION Y-Y  
HORSESHOE TYPE**

**GENERAL NOTES:**

1. THIS STANDARD DETAIL DESCRIBES THE USE OF HORSESHOE TYPE and CORED MANHOLES WITH A CAST-IN-PLACE BOTTOM.
2. USE HORSESHOE TYPE MANHOLE ONLY WITH THE PERMISSION OF THE ENGINEER.
3. FOR HORSESHOE TYPE MANHOLES, WRAP THE PIPE WITH BUTYL RUBBER GASKET, AND SEAL WITH NONSHRINKING GROUT.

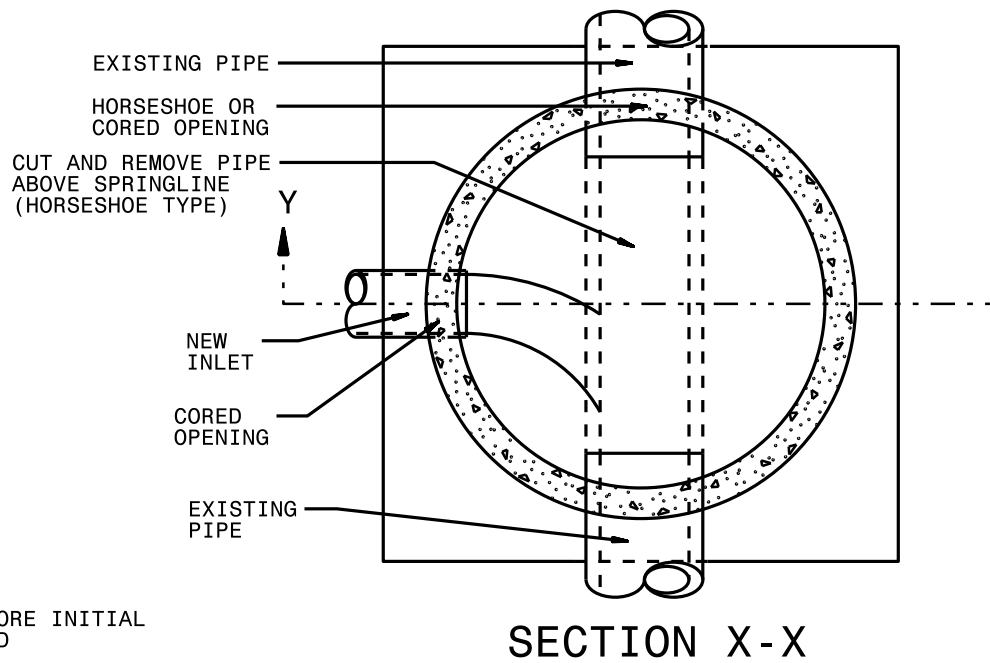

**SECTION X-X**

ROADWAY STANDARD DRAWING FOR

**PRECAST CONCRETE  
SANITARY SEWER MANHOLE  
WITH CAST-IN-PLACE BOTTOM**

1-24

STATE OF  
NORTH CAROLINA  
DEPT. OF TRANSPORTATION  
DIVISION OF HIGHWAYS  
RALEIGH, N.C.

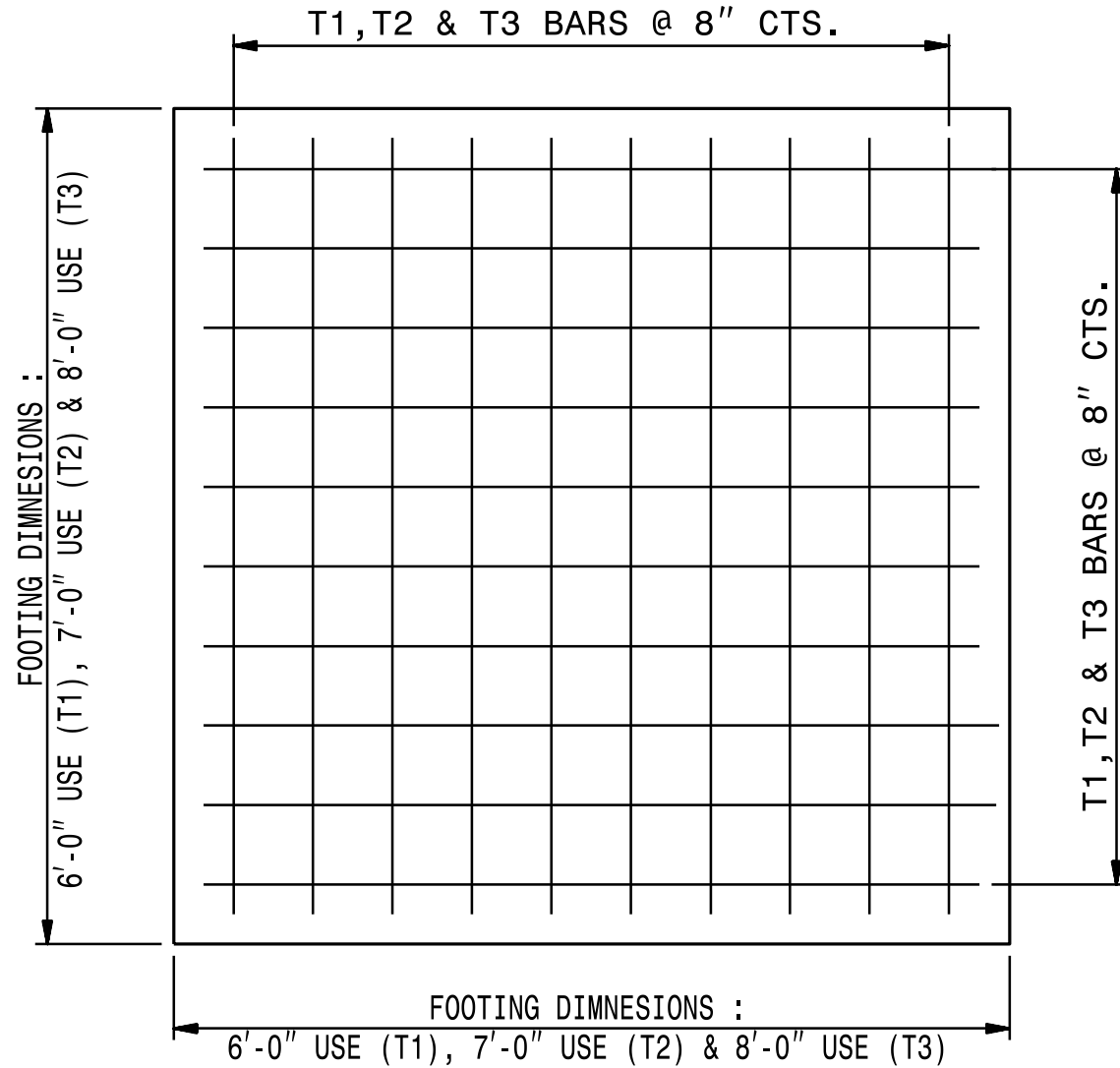

**REINFORCED CONCRETE FOOTING  
FOR 4' PRECAST MANHOLE  
5' PRECAST MANHOLE OR  
6' PRECAST MANHOLE**

BILL OF MATERIAL FOR 6'-0" FOOTING				
BAR	SIZE	LENGTH	NO.	WT. lbs.
T1	#5	5'-6"	18	103
CLASS "A" CONC. YD <sup>3</sup> 9" THICK				1.00
BILL OF MATERIAL FOR 7'-0" FOOTING				
BAR	SIZE	LENGTH	NO.	WT. lbs.
T2	#5	6'-6"	20	136
CLASS "A" CONC. YD <sup>3</sup> 9" THICK				1.36
CLASS "A" CONC. YD <sup>3</sup> 12" THICK				1.82
BILL OF MATERIAL FOR 8'-0" FOOTING				
BAR	SIZE	LENGTH	NO.	WT. lbs.
T3	#5	7'-6"	24	188
CLASS "A" CONC. YD <sup>3</sup> 12" THICK				2.37

PLACE REINFORCING STEEL SO THAT STEEL IS PLACED A MIN. OF 2" AND A MAX. OF 4" FROM THE TOP OF THE SLAB.

